

# SURVEY ON ACCIDENT MONITORING SYSTEM

P. S. Bangare<sup>1</sup>, Y. S. Petare<sup>2</sup>, A. P. Chaudhari<sup>3</sup>, R. D. Jadhav<sup>4</sup>, S. L. Bangare<sup>5</sup>,  
<sup>1,2,3,4,5</sup> Dept. of I.T.,  
Sinhgad Academy of Engineering, India  
**sunil.bangare@gmail.com (Corresponding Email ID),**  
petareyash@gmail.com

## ABSTRACT

Nowadays we are able to track vehicles using many applications which help in securing personal vehicles, public vehicles, feet units and others. Furthermore there is a rapid increase in the occurrence of the Road accident. This paper is about a system which is developed to automatically detect an accident and alert the nearest hospitals and medical services about it. This system can also locate the place of the accident so that the medical services can be directed immediately towards it. Data from different sensors is updated on the webpage.

**Keywords-** accident detection; alert system; vibration, Webpage, GSM modem

## I. INTRODUCTION

Transportation has awesome significance in our day by day life and its advancement has made huge numbers of our errands much simple. Be that as it may, it can make calamity us and even can murder us through mishances. Amid 2008, Road Traffic Injuries positioned fourth among the main sources of death on the planet. Almost 1.3 million individuals kick the bucket each year on the world's streets and 20 to 50 million individuals endure non-lethal wounds, with many supporting a handicap because of their damage. Street movement wounds are the main source of death among youngsters matured 15-29 years and cost nations 1-3% of the total national output (GDP). In the event that no move is made, street car accidents are anticipated to result in the passings of around 1.9 million People yearly by 2020. At the point when an individual riding his/her bicycle, meets with a mishap, quite possibly the individual may experience the ill effects of genuine damage or lapse momentarily and there is nobody around to encourage him. Well this framework is an answer for the issue. The framework goes about as a mischance distinguishing proof framework that accumulates and sends this vehicle data that met with a mishap, and passes on it to the closest police control room and emergency vehicle.

## II. LITERATURE SURVEY

The Expected execution is accomplished through usage of the proposed framework. The sensor and other required parts are appropriated all through the auto giving more ideal outcomes to recognize mishaps. The proposed framework can likewise be utilized for movement estimation and framework execution estimation to avoid death toll to its most extreme. [1]

An Embedded System is planned which can be most helpful for Accidents. It's an ease, Power effective framework by which the activity time can be limited and correct area of a mischance can likewise be characterized with GPS benefit and furthermore the data in regards to mishap can be sent to specific contact numbers e.g., Police stations, Doctors and so forth.. On account of the adaptability of installed framework, this framework is especially perfect to any sort of vehicles. Over this framework is especially reasonable to a typical man and this can be effortlessly executed. [2]

This task presents vehicle mishap identification and ready framework with SMS to the client characterized portable numbers. The GPS following and GSM caution based calculation is planned and actualized with

LPC2148 MCU in implanted framework area. The proposed Vehicle mishap discovery framework can track land data naturally and sends a ready SMS with respect to mishap. [3]

This undertaking presents vehicle mishap recognition and ready framework with SMS to the client characterized versatile numbers. The GPS following and GSM alarm based calculation is outlined and executed with LPC2148 MCU in implanted framework area. The proposed Vehicle mishap identification framework can track land data consequently and sends a ready SMS with respect to mishap. Test work has been completed painstakingly. [4]

Mishap based crisis situation can be detected by our insightful application in Android portable utilizing an accelerometer and ready message which contains the GPS area data was sent through SMS, email and message can be effectively posted on particular user's Facebook divider. Subsequently, Android indeed turned out to be a flexible working framework which enabled us to control different inbuilt highlights of an Android portable which made us to build up a smart application called as ETS. [5]

The possibility of vehicle mishap recognition isn't new and the car organizations have gained heaps of ground in idealizing that innovation. The paper [6] is an endeavor to contribute here of innovation. Here we are endeavoring to identify mishap through three parameters-speeding up/deceleration, tilt of the vehicle and the weight change on the body of the vehicle. Utilizing these moment information esteems and an able calculation, the mishap can be identified with a sensible achievement rate. Also, the directions of the vehicle discovered utilizing GPS innovation is sent to the crisis administrations for help.

The framework proposed in [7] can identify the mishap and affirms the reality of the mishap and after that alarm the closest restorative help focus to give crisis therapeutic guide to mishap casualty. Accelerometer and heartbeat sensor are utilized to 2017 International Conference on Computer Communication and Informatics (ICCCI - 2017), Jan. 05 – 07, 2017, Coimbatore, INDIA decide if a mishap had happened. The correspondences between the modules are finished by utilizing Bluetooth. The advanced cell with the android application will send message to the closest restorative focus. The framework will likewise illuminate the loved ones of the casualty through message. A signal is additionally given to caution the kindred travelers out and about that a mishap has jumped out at welcome their assistance. Pre-emption of the mishaps occurring on the streets isn't conceivable, yet in any event the delayed consequences can be limited. The framework proposed in [8] guarantees making crisis offices accessible to mishap casualties as ahead of schedule as conceivable by letting relatives; by the method for checking the auto utilizing its number plate perceives the camera. Before that it can act through the tollbooth, the vehicle number plate was caught by this camera and stores it in a database. It will look at that the vehicle was approved or not, if the number plate was enrolled one, at that point it passes the section to the vehicle, generally bell caution will rise. At the point when the auto met a mishap sense by vibration sensor making a caution to doctor's facility or a safeguard group knows the mishap spot with the assistance of this module installed in the vehicle.

The Rapid development of innovation has made our life less demanding. This headway in innovation additionally expanded the activity risks. Thus the proportion of street mishaps which occur every now and again builds causing enormous death toll because of poor crisis offices. Research completed in [9] gives an answer for mishap recognition and counteractive action for human life security. It empowers wise location of a mishap at wherever and reports about the mishap on predefined numbers. The equipment incorporates vibration sensor, three modules GPS recipient, Microcontroller (Lpc2148), and PIC 16F877A GSM modem (SIM 800). Pulse sensor when a vehicle faces mishap quickly vibration sensor will recognize the flag and after that Microcontroller sends the alarm message through the GSM modem including the area to predefined numbers that can be held for a protect group. And keeping in mind that returning through ultrasonic sensor the movement light will be control.

Mishap debilitates human lives progressively and predominantly street mishap is normal today. Amid mishap numerous individuals lose their life since therapeutic administrations and relative not getting unplanned data on time. Framework displayed in [10] is a productive vehicle remote framework which planned and

executed for vehicle mischance recognition and detailing utilizing accelerometer and GPS. Accelerometer sensor is utilized to identify crash and GPS give area of vehicle. If there should be an occurrence of any mishap, the framework send computerized message to the pre-modified number, for example, relative or crisis medicinal administrations by means of GSM. P. S. Bangare et al have worked on the Online Home Security model [11].

### III. PROPOSED SYSTEM

Following figure demonstrates the squares of proposed framework. The fundamental issue with existing message situated mischance framework is that it makes an impression on power regardless of whether little mishap happens. For this situation when specialist landed at area, the harmed individual as of now escapes from the place. This disturbs approved individual. To evade this we utilized ringer which will remain ON for 2 minutes. A chafing sound plays through ringer at whatever point a man meets a mischance, on the off chance that he isn't genuinely injured, at that point he will squeezed change to stop signal. On the off chance that the ringer doesn't stop that implies the mischance is not kidding one and sends the alarm message with area (caught by means of GPS) to power. There is plausibility of absence of system or a mishap may happens in no system zone all things considered voice recompense module begins to play a computerized message which contains name, address and gatekeepers contact no. at whatever point PIR module identifies a going by individual. Another gathering of sensors which distinguishes the seriousness of mischances are temperature sensor, vibration sensor and small scale switch. A high temperature recognizes fire in vehicle, mishaps makes more vibration in auto in this way vibration above limit is likewise one of the notice of significant mischance. At whatever point a vehicle falls in water vibration sensor isn't powerful and henceforth we utilize small scale switch which change state in light of weight from water. All information is refreshed on site page after normal interim of time.

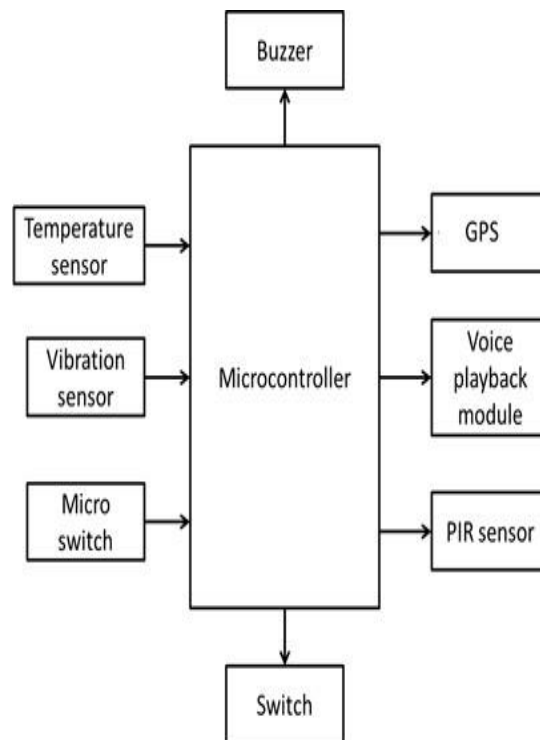

Fig 1: block diagram of proposed system

#### IV. FLOW CHART

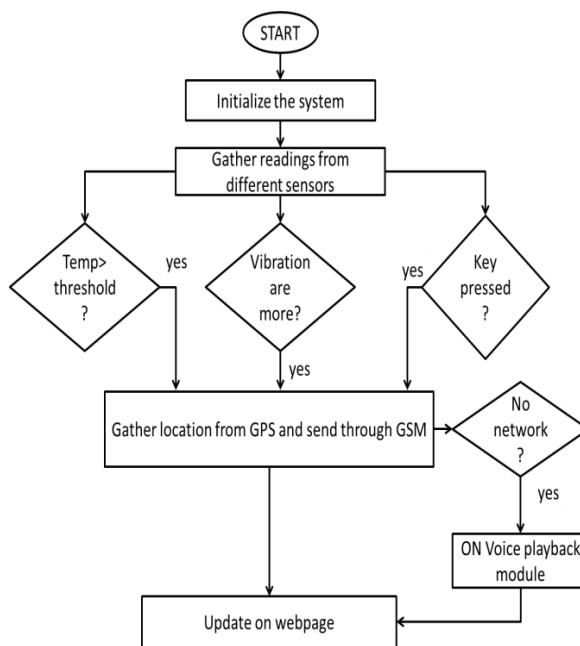

Fig 2 flowchart of proposed system

#### V. ADVANTAGES

1. This system eliminates drawback of previous accident alerting system as this system didn't send any message if the accident is not a fatal one.
2. Severity of accident is detected by additional 3 sensors connected to system
3. System tries to contact with surrounding people even if there is no network by using voice playback module.

#### VI. CONCLUSION

With this system, an Embedded System is designed which can be most useful for Accidents. It's a low cost, Power efficient system by which the action time can be minimized and exact location of an accident can also be defined with GPS service and also the information regarding accident can be sent to particular contact numbers e.g., Police stations, Doctors etc..Because of the flexibility of embedded system, this system is very much compatible to any kind of vehicles. Over all this system is very much affordable to a common man and this can be easily implemented.

#### REFERENCES

- [1] Ajith Kumar.A , Jaganivasan.V , Sathish.T, Mohanram. S., "Accident detection and alerting system using GPS & GSM ", International Journal of Pure and Applied Mathematics Volume 119 No. 15 2018, 885-891.
- [2] Kajal Nandaniya, Nadiad V. Choksi, Ashish Patel, M B Potdar, "Automatic Accident Alert and Safety System using Embedded GSM", Interface International Journal of Computer Applications (0975 – 8887) Volume 85 – No 6, January 2014,26.
- [3] Hemangi S. Ahire , Madhuri B. Kamble et al., "Vehicle Accident Detection and Alerting System", International Journal for Research in Applied Science & Engineering Technology (IJRASET) ISSN: 2321-9653; IC Value: 45.98; SJ Impact Factor:6.887 Volume 6 Issue I, January 2018 Reserved 67
- [4] C. Prabha, R.Sunitha, R.Anith, "Automatic Vehicle Accident Detection and Messaging System Using GSM and GPS Modem", International Journal of Advanced Research in Electrical, Electronics and Instrumentation Engineering, Vol. 3, Issue 7, July 2014 Copyright to IJAREEIE, 10723 DOI: 10.15662/ijareeie.2014.0307062
- [5] Megha Nirbhavane, Shashi Prabha, "Accident Monitoring System using Wireless Application", International Journal of Advanced Research in Computer Engineering & Technology (IJARCET) Volume 3 Issue 4, April 2014.
- [6] Fahim Bin Basheer, Jinu J Alias, et al, "Design of Accident Detection and Alert System for Motor Cycles", 978-1-4799-1095-3/13/\$31.00 ©2013 IEEE

- [7] Nicky Kattukkaran, Arun George, Mithun Haridas T.P, “Intelligent Accident Detection and Alert System for Emergency Medical Assistance”, 2017 International Conference on Computer Communication and Informatics (ICCCI -2017), Jan. 05 – 07, 2017, Coimbatore, INDIA
- [8] S. Suganya , T. Divya , M. Subha Sankari, P.Gomath, “Tracking down the Vehicle Collision Detection and Messaging System using GPS and GSM”, International Journal of Engineering Research & Science (IJOER) ISSN: [2395-6992] [Vol-4, Issue-3, March- 2018] Page 61.
- [9] Varsha Kshirsagar, Ajay Gavhande, Shubham Deshmukh, Yogesh Daswadkar, “Accident Detection and Alerting System with Rescue of Ambulance”, International Journal of Innovative Research in Computer and Communication Engineering Vol. 5, Issue 5, May 2017 Copyright to IJRCCE DOI: 10.15680/IJRCCE.2017. 0505159 9630.
- [10] Shailesh Bhavthankar, H. G. Sayyed, Vehicle “Wireless System for Accident Detection and Reporting using Accelerometer and GPS”, International Journal of Scientific & Engineering Research, Volume 6, Issue 8, August-2015 1069 ISSN 2229-5518 IJSER © 2015 <http://www.ijser.org>
- [11] Pallavi S. Bangare, A. Pote, S. L. Bangare, P. Kurhekar and D. Patil, “The Online Home Security System: Ways to Protect Home from Intruders & Thefts”, International Journal of Innovative Technology and Exploring Engineering (IJITEE), ISSN: 2278-3075, Volume-2, Issue-3, 2013.